

Model 53.01



Use

Model 53.01 is a sliding pass-through that comes ready for installation and comprises an integrated two-way intercom system. The unit is frequently used for physical access supervision in indoor areas and roofed outdoor areas such as car parks, gatehouses, government buildings and company gates. M3/FB4 firearm certification comes as standard. Fire protection to F90 available on request.



Safety and features

- Sliding pass-through for pedestrians, fits flush with outside façade; front panel and integrated intercom for automatic two-way conversation.
- Manual operation drawer.
- Locks automatically in both end positions. Lock can only be released by the operator behind the counter by using the lever.
- It is not possible to reach through the hole when the drawer is extended or manipulate the mechanism.
- For handing over passes, files etc up to DIN A4.
- Dust and draught sealed.
- Materials offer firearms protection, capable of withstanding heavy handgun fire, e.g. up to 44 Magnum. Has received M3/FB4 certification from the firearms licensing authority.
- Model 53.01 fulfils German UVV regulations.

Materials and use

- Steel plate pass-through.
- Fascia and drawer made out of 1mm thick brushed stainless steel, casing, cover and lid 2 mm thick.
- All metal parts have been produced using state-of-the-art precision laser cutting technology for ultimate quality.
- Model 53.01 is suitable for indoor and outdoor use in covered areas.
- The unit requires no maintenance. No need for cleaning or lubrication.

Outdoor use

Outer dimensions

(all measurements in mm)

Front panel 670 x 130 x 28

Pass-through

Width 420

Depth 400

Height 63

Drawer

Width 320

Depth 215

Height 38

Extension 220

Weight

26kg

Miscellaneous

- Model 53 available without two-way intercom and, as desired, with or without front fascia.
- Available up to F90 fire protection.
- Firearm certification FB6 available on request (Model 63.01).
- Available with rain cover.
- Special sizes available on request.
- Coatings available in RAL colours on request.

Walter Wurster GmbH

Heckenrosenstraße 38

D-70771 Leinfelden-Echterdingen

Germany

Telefon: +49 (0) 711 / 9 49 62-0

Telefax: +49 (0) 711 / 7 97 72 90

e-mail: kontakt@IdeeninBlech.de

internet: www.IdeeninBlech.de

Model 53.01

Installation and dimensions

The unit comes ready for mounting in prepared walls/façade recesses. Coming from the outside, it is mounted by inserting into the recess before screwing tight underneath the unit on the inside. Consideration must be given to access requirements and the possible need to remove the unit later in the unlikely event of repairs.

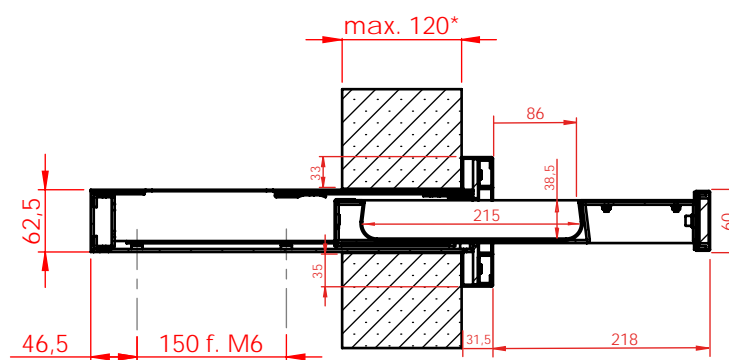

* with cranked drive lever

