

Model 11



Use

Model 11 is a flat receipt and payment tray that comes ready for installation. Ideally it should be used as an indoor counter unit. The tray is suitable for handing over receipts, documents and small amounts of loose change.

Safety and features

- Ready-for-mounting tray for handing over flat items such as files to a maximum size of DIN A4, receipts, documents, passports and rolls of coins up to 30mm high.
- User-friendly edges for removing coins.
- Model 11 fulfils German UVV regulations.

Materials and use

- Flat tray consists of a black skin plate.
- Surround made out of 2mm thick brushed stainless steel.
- All metal parts have been produced using state-of-the-art precision laser cutting technology for ultimate quality.
- Model 11 is best suited to internal use.
- This receipt and payment tray requires no maintenance. No need for cleaning or lubrication.

Payment trays

Outer dimensions

(all measurements in mm)

Width 320

Depth 480

Height 42

Tray clearance

Width 240

Height 30

Mounting: counter section

Model 11 305 x 420 x 40

Weight

5.6kg

Miscellaneous

- Model 11 is designed to go with Model 15

Model 11

Installation and dimensions

The receipt and payment tray comes ready for mounting in prepared counter sections. The tray is mounted by inserting it into the recess in the counter from above. Consideration must be given to access requirements and the possible need to remove the unit later in the unlikely event of repairs.

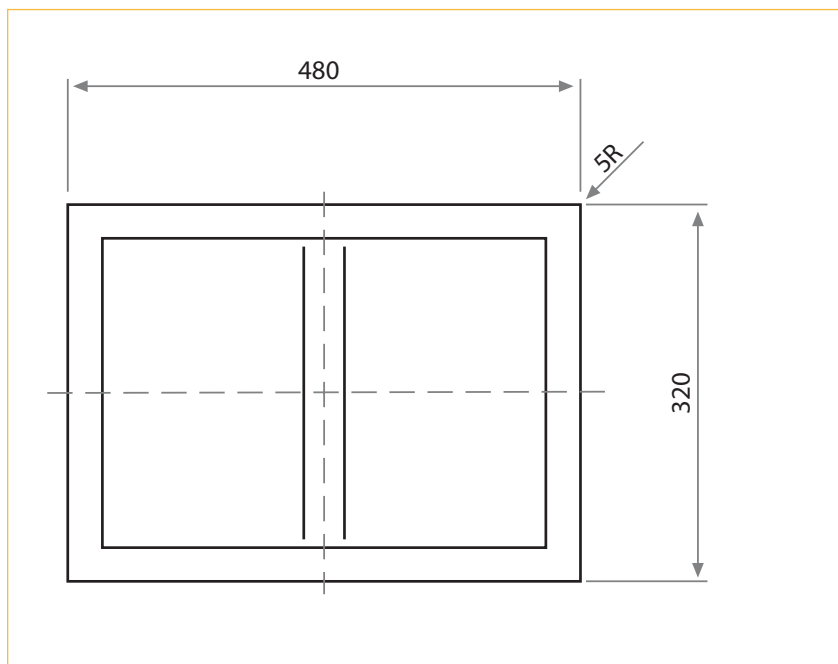
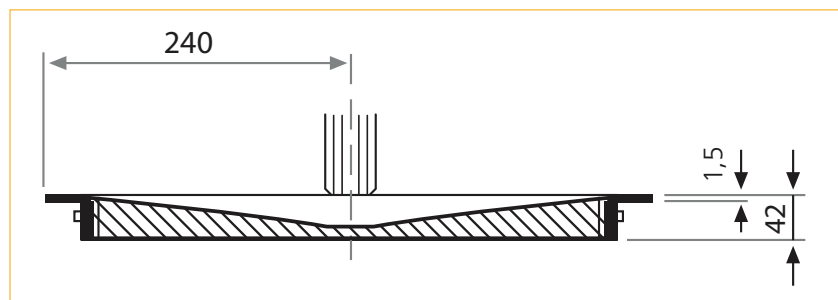

Walter Wurster GmbH

Heckenrosenstraße 38

D-70771 Leinfelden-Echterdingen

Germany

Telefon: +49 (0) 711 / 9 49 62-0

Telefax: +49 (0) 711 / 7 97 72 90

e-mail: kontakt@IdeeninBlech.de

internet: www.IdeeninBlech.de